

# TANKO® S50

The TANKO® S family offers significant potential savings, excellent cleaning results and product safety.

The S50 part of this TANKO® family is a media driven rotating surge cleaning head

AWH's state of the art design and their quality of manufacture ensures these excellent results required in today's process and manufacturing industries.

The S50's broader and accurate slits create consistent and large virtually round droplets. These droplets impacting on the vessel walls, combined with a smooth rotation speed ( thanks to the action of the double race ball bearings) creates the high impact required.



## Typical Applications

- ⇒ Medium vessels
- ⇒ Ducting
- ⇒ Process tanks
- ⇒ Combination fitting for larger tanks / areas



360°



180° upwards



180° downwards



270° upwards

TANKO® S50 Specification	
Type of cleaning	surge cleaning
Coverage	180°, 270°, 360°
Mode of drive	cleaning media driven
Drive support	double ball bearings
Installation Position	freely selectable
Max rec. cleaning diam.	1.0 - 6.0 mtrs
Operating pressure	2.0 - 10.0 bar
Thread	1.1/4" BSP, NPT, 1.1/2" BSP, NPT, NPS Clip-on : Weld-on
Max. working temp	230°C
Max. ambient temp	250°C

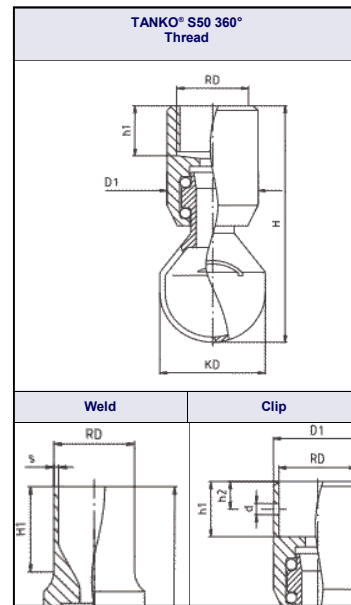

Connection	DN mm	RD ømm	S mm	KD ømm	H mm	h1 mm	h2 mm	d ømm
Clip on	40	41.5	~	69.5	172	35.2	24.2	5.5
Clip on	50	54.3	~	69.5	158	19	10	5.5
Clip on	40	49.6	~	69.5	158	19	10	5.5
Clip on	40	52.0	~	69.5	158	19	10	5.5
Clip on	40	51.0	~	69.5	158	19	10	5.5
Weld	50	53.0	1.5	69.5	180	34	~	~
Weld	40	41.0	1.5	69.5	180	27	~	~
Weld	40	48.3	2.0	69.5	180	31	~	~
Weld	50	60.3	2.0	69.5	180	31	~	~
Weld	40	50.8	1.65	69.5	180	32	~	~
Weld	50	54.0	2.0	69.5	180	34	~	~
Weld	32	38.0	1.2	69.5	180	27	~	~
Weld	40	51.0	1.2	69.5	180	32	~	~
Thread	32	1.1/4" BSP	~	69.5	158	21	~	~
Thread	32	1.1/4" NPT	~	69.5	158	21	~	~
Thread	40	1.1/2" BSP	~	69.5	158	21	~	~
Thread	40	1.1/2" NPT	~	69.5	158	21	~	~

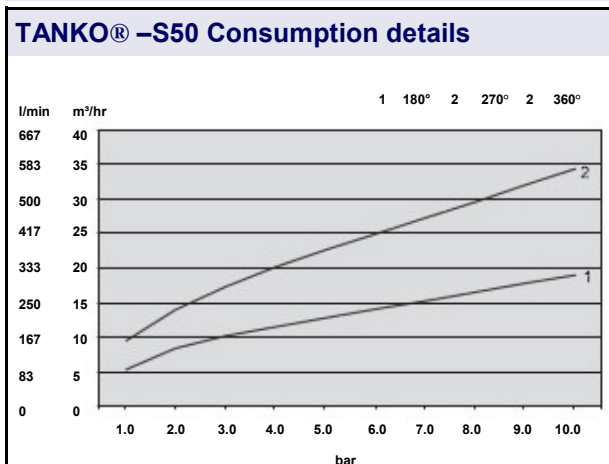

Refer to the AWH Catalogue connection on ICS web site  
for further information and the full CIP / tank cleaning experience  
[www.icsindustrialservices.co.uk](http://www.icsindustrialservices.co.uk)



ICS (INDUSTRIAL SERVICES) Ltd Tel: +44 (0) 1244 371167 Fax: +44 (0) 1244 372497  
Email: [sales@icsindustrialservices.co.uk](mailto:sales@icsindustrialservices.co.uk) web: [www.icsindustrialservices.co.uk](http://www.icsindustrialservices.co.uk)