

DNH

Features

- Conventional model to produce higher impact force.

Maximum working pressure

- 25 MPa

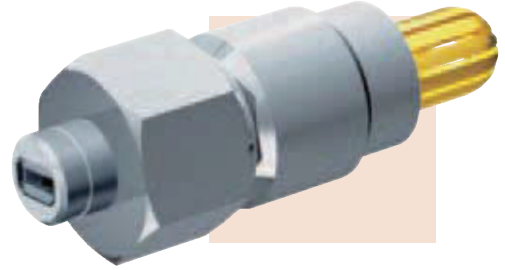

Shapes & dimensions

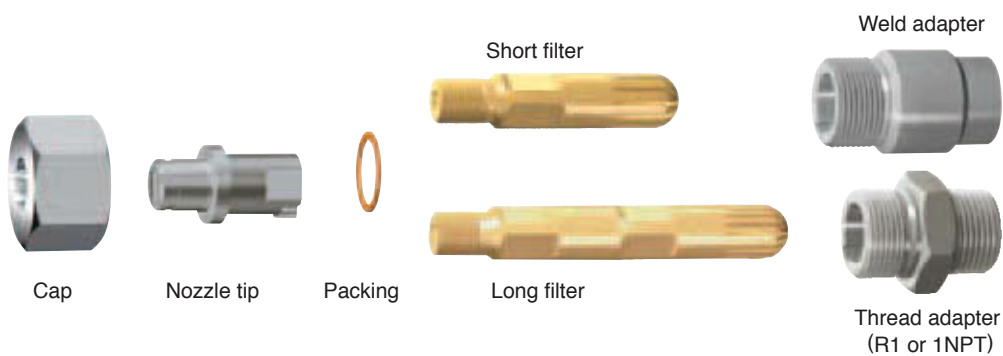
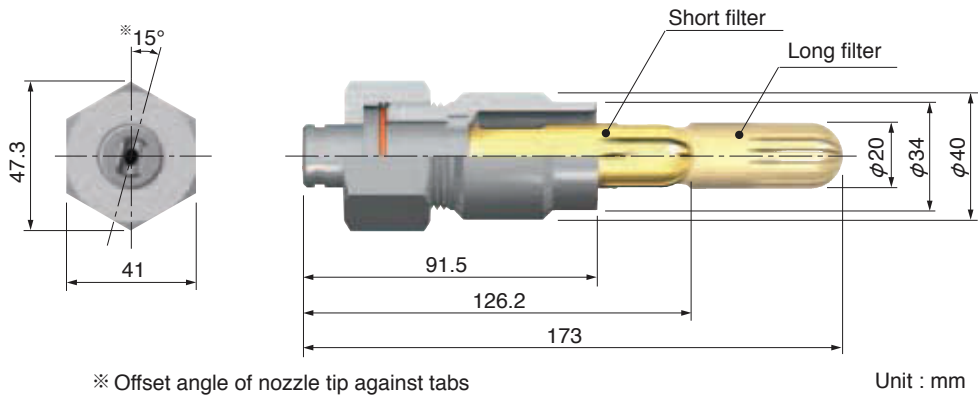

Part	Material	Weight [g]
Cap	303 Stainless steel	150
Nozzle tip	Tungsten carbide & 303 SS	115
Packing	Copper	4
Short filter	Brass	120
Long filter	Brass	215
Weld adapter	304 Stainless steel	255
Thread adapter	304 Stainless steel	215