

DNK

Features

- The trumpet shaped orifice is based on high hardness Tungsten Carbide for extra wear resistance.
- A straightening filter provides a uniform high impact force distribution.



Maximum working pressure

- 50 MPa

Shapes & dimensions

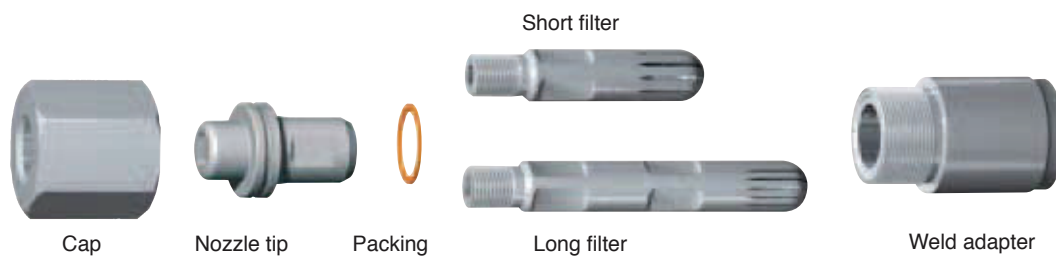
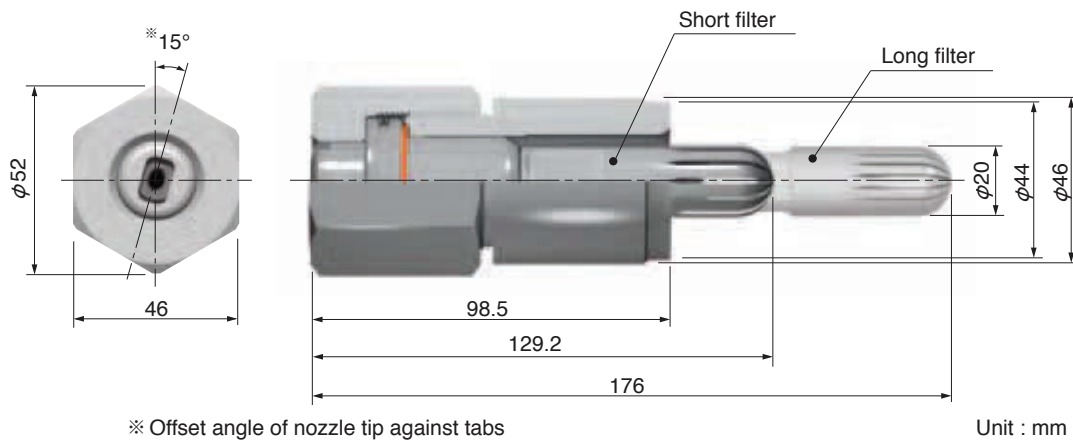

Part	Material	Weight [g]
Cap	303 Stainless steel	345
Nozzle tip	High hardness tungsten carbide & 303 SS	180
Packing	Copper	5
Short filter	303 Stainless steel	113
Long filter	303 Stainless steel	203
Weld adapter	304 Stainless steel	530