

# TANKO® S40

The TANKO® S family offers significant potential savings, excellent cleaning results and product safety.

The S40 part of this TANKO® family is a media driven rotating surge cleaning head

AWH's state of the art design and their quality of manufacture ensures these excellent results required in today's process and manufacturing industries. The S40's broader and accurate slits create consistent and large virtually round droplets. These droplets impacting on the vessel walls, combined with a smooth rotation speed ( thanks to the action of the double race ball bearings) creates the high impact required.

The TANKO® S40 HF variation gives a higher flow whilst offering the same operating configurations

## Typical Applications

- ⇒ Small, medium vessels
- ⇒ Large casks / barrels
- ⇒ Ducting
- ⇒ Process tanks
- ⇒ Combination fitting for larger tanks / areas

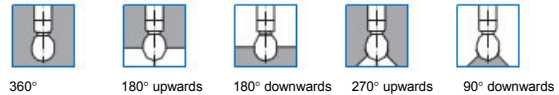

TANKO® S40 Specification	
Type of cleaning	surge cleaning
Coverage	90°, 180°, 270°, 360°
Mode of drive	cleaning media driven
Drive support	double ball bearings
Installation Position	freely selectable
Max rec. cleaning diam.	0.5 - 4.0 mtrs
Operating pressure	1.0 - 9.0 bar
Thread	1/4" BSP, NPT, 3/8" BSP, NPT, NPS Clip-on : Weld-on
Max. working temp	230°C
Max. ambient temp	250°C

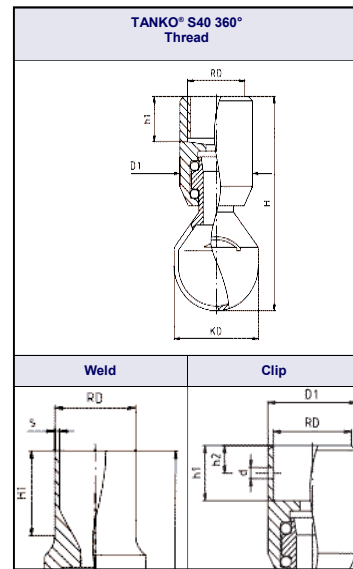

Connection	Standard DIN 11866	DN	RD ømm	S mm	KD ømm	H mm	h1 mm	h2 mm	d ømm
Clip on	Series A (DIN)	20	23.5	~	39.0	93	19	10	4.0
Clip on	Series A (DIN)	25	29.5	~	39.0	93	19	10	4.0
Clip on	Series B (ISO)	20	27.5	~	39.0	93	19	10	4.0
Clip on	Series B (ISO)	25	34.2	~	39.0	93	19	10	4.0
Clip on	Series c (ASME)	20	26.0	~	39.0	93	19	10	4.0
Clip on	Series 1 (DIN 11850)	20	22.6	~	39.0	93	19	10	4.0
Clip on	Series SMS	20	25.3	~	39.0	93	19	10	4.0
Weld	Series A (DIN)	15	19.0	1.5	39.0	108	27	~	~
Weld	Series A (DIN)	20	23.0	1.5	39.0	108	27	~	~
Weld	Series A (DIN)	25	29.0	1.5	39.0	108	29	~	~
Weld	Series B (ISO)	20	26.9	1.6	39.0	108	28	~	~
Weld	Series B (ISO)	25	33.7	2.0	39.0	108	34	~	~
Weld	Series SMS	20	25.0	1.2	39.0	108	28	~	~
Weld	Series C	15	3/4"	1.65	39	108	27	~	~
Weld	Series C (ASME)	20	1" (25.4)	1.65	39	108	28	~	~
Thread	BSP	15	G1/2"	~	39.0	93	19	~	~
Thread	BSP	20	G3/4"	~	39.0	93	19	~	~
Thread	NPT	15	1/2"	~	39.0	93	19	~	~
Thread	NPT	10	3/4"	~	39.0	93	19	~	~

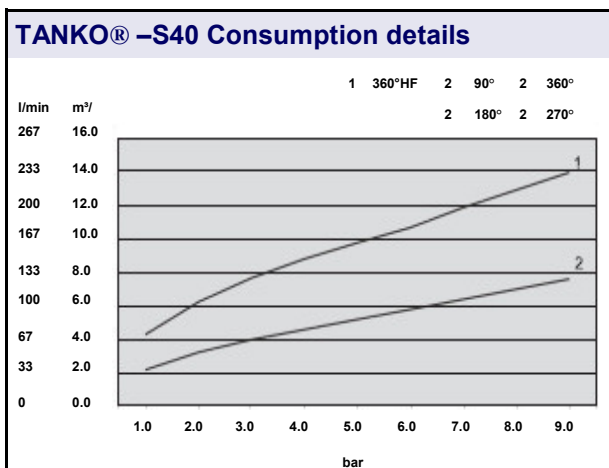

Refer to the AWH Catalogue connection on ICS web site  
for further information and the full CIP / tank cleaning experience  
[www.icsindustrialservices.co.uk](http://www.icsindustrialservices.co.uk)



ICS (INDUSTRIAL SERVICES) Ltd Tel: +44 (0) 1244 371167 Fax: +44 (0) 1244 372497  
Email: [sales@icsindustrialservices.co.uk](mailto:sales@icsindustrialservices.co.uk) web: [www.icsindustrialservices.co.uk](http://www.icsindustrialservices.co.uk)